

Getting the Most from IC Voltage References

A brief guide for users

by Walt Jung

As resolution and accuracy requirements of modern systems rise to 12 bits and beyond, the selection, specification, and application of voltage references becomes a key factor in system design. This article, devoted to designing with IC references, starts with the basic features of a good reference, discusses reference performance parameters, and concludes with examples of IC reference applications in high-performance circuits.

REFERENCE BASICS

Figure 1 depicts an ideal 1-volt reference source. This source is ideal in the sense that the 1.000000-V output is independent of time, temperature, and other environmental factors. Furthermore, neither connection polarity nor loading affects the voltage it delivers to the load. In this ideal world, connection of load, R_L , with either polarity, produces a constant voltage at the load, equal in magnitude to the original source, V_R .

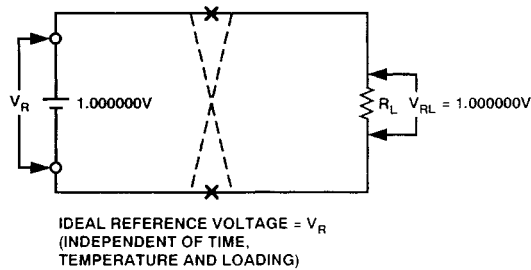

Figure 1. Ideal reference-voltage source.

In the real world, all the factors assumed ideal can and will vary. Major sources of error in reference voltage include initial calibration tolerance, output voltage drift with temperature and time, loading effects (characterized by output and wiring impedances), and noise components (both intrinsic and supply-related).

A variety of ways exist to produce a relatively stable voltage, including chemical, solar and low-temperature quantum devices. As a starting point, we will restrict our discussions to reference sources derived from system power, and in particular to reference circuits powered from positive or negative 3-30-volt dc supplies.

Most commonly, standard reference ICs are available in *three-terminal* form (V_{IN} , Common, V_{OUT}), with positive polarity. *Two-terminal* (diode-like) references, while more flexible regarding polarity, are restrictive as to loading. The constraints often complicate reference designs, making choices difficult (but inviting ingenuity).

Some basic two-terminal references are shown in Figure 2. In (a), a current-driven forward-biased diode (or diode-connected transistor) produces a voltage, V_F , approximately proportional to the logarithm of current and hence relatively insensitive to small changes in current. While its junction drop is somewhat independent of the raw voltage supply, it has numerous deficiencies as a reference. Among them are a significant temperature coefficient (TCV) of about $-0.3\%/^{\circ}\text{C}$, some sensitivity to loading, and a rather

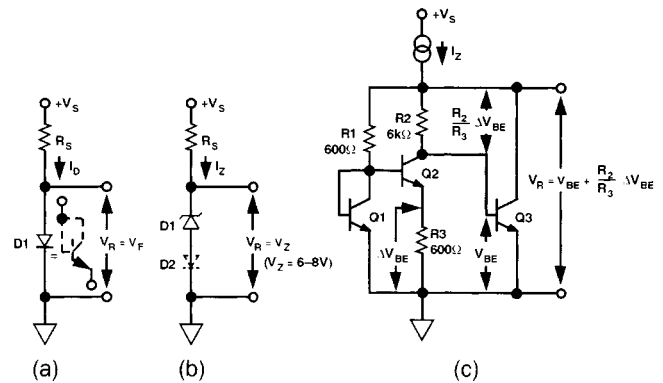

Figure 2. Basic semiconductor reference circuits. a. Simple forward-biased diode. b. Zener (avalanche) diode reference. c. Basic bandgap reference.

limited output voltage, about 600 mV; multiples of this voltage can be obtained by using series-connected junctions.

By contrast, this simple reference (as well as other shunt-type two-terminal regulators) has a basic advantage—that polarity can be readily inverted by reversing connections and drive current. However, a basic limitation of all shunt regulators is that driving current, I_D , does not decrease substantially when load current decreases.

In (b), by driving an appropriately selected reverse-breakdown diode at a current exceeding a threshold, an appreciably higher reference voltage can be realized. Although such reference diodes are almost universally referred to as “Zener” diodes, true Zener breakdown occurs below 5 V, while avalanche breakdown occurs at higher potentials.[1] With D1 chosen to have breakdown voltage in the 5-to-8-V range, its net positive TC adds to the negative TC of a series forward diode (D2), yielding a net TC of 100 ppm/ $^{\circ}\text{C}$ or less with proper current bias.[2] In the past, carefully chosen diodes were combined to form single-package “zero-TC Zener references”, such as the 1N821-1N829 series. Designs based on this concept were the basis for early hybrid IC references, which are in fact still sold today (more below).

While low TC can be realized in 2(b), the circuit has limitations on direct use of its output: First, the choice of voltage with high-accuracy diodes is limited, because the best TC combinations occur at specific voltages, such as the 1N829’s 6.2 V. In addition, the range of load currents is limited, since the diode current must be carefully controlled for best TC. And, unlike a fundamentally low-voltage ($<2\text{-V}$) reference such as 2(a), Zener-diode-based references must of necessity be driven from voltage sources appreciably greater than 6 V, so this precludes their operation from 5-V system supplies. References based on old-style low-TC avalanche diodes tend to be noisy, an inherent property of the surface-breakdown mechanism. This noise is lower with monolithic buried-Zener types (more below).

The development of low-voltage ($<5\text{-V}$) reference circuits based on the bandgap* voltage of silicon led to the introduction of ICs that could provide good TC performance operating on low voltage supplies.[3] A bandgap reference develops an internal voltage proportional to absolute temperature (PTAT) to null out the temperature variation of a junction voltage, which has a negative TC (complementary to absolute temperature—CTAT). A basic

*The bandgap is the energy difference between the bottom of the conduction band and the top of the valence band. For references using silicon transistors the corresponding voltage, extrapolated to $T = 0\text{ K}$, is about 1.21 V—but is dependent on process and detailed curvature-compensation circuitry.

bandgap-based reference cell, driven by a constant current, is shown in Figure 2 (c). This circuit is also called a “ ΔV_{BE} ” reference, because of the correction voltage across R2. This voltage, based on the V_{BE} difference produced by differing current densities between matched transistors, Q1-Q2, is developed by a current resulting from ΔV_{BE} across R3 and transduced to voltage by R_2 . It is summed with the V_{BE} of Q3 to produce V_R .

The bandgap technique is attractive in low-voltage IC designs because it is relatively simple and avoids noisy Zeners. It is used both for stand-alone IC references and as an internal reference within linear ICs. Buffered forms of 2-terminal 1.2-V reference ICs employing the bandgap concept provide additional current gain for stable, accurate operation over wide current ranges. Among them is the AD589, a synthesized 1.235-V “diode” with a 0.6- Ω dynamic impedance, a 50 μ A to 5 mA operating current range, and TC grades ranging from 10 to 100 ppm/ $^{\circ}$ C.

The basic designs shown in Figure 2 are sensitive to loading and require stable current drive. They generally need scaling of the output to more-useful levels, e.g., 2.5 V, 5 V, etc. For most applications, a buffer amplifier is used; besides driving loads, it provides voltage scaling to more useful levels.

An improved bandgap circuit (Figure 3), the “Brokaw cell”, addresses these issues.[4, 5] This circuit is used in the AD580, the first precision bandgap-based IC reference. Still in production after 20 years, it is the first of a family of reference devices, such as the AD581 and AD584; the circuit also provides the internal reference in many Analog Devices ADCs and DACs.

At the heart of the AD580 are two transistors, Q2 and Q1, with equal collector currents and 8:1-scaled emitter areas (resulting in a 1:8 current-density ratio). The currents are maintained equal by matched load resistors and overall feedback voltage from the output amplifier (which also provides buffering), applied to the transistor bases. In this closed loop, the difference in the V_{BE} s (i.e., ΔV_{BE})

appears across R2, and a current equal to $2\Delta V_{BE}/R_2$ flows through R1, producing a PTAT voltage, V_1 :

$$V_1 = 2 \frac{R_1}{R_2} \Delta V_{BE}$$

V_1 appears in series with V_{BE} , thus a constant voltage, V_Z (about 1.205 V)—appropriately compensated for the variation of V_{BE} with temperature—appears between the bases and common.

The feedback attenuator, R4 and R5 (laser trimmed) permits the actual voltage appearing at V_{OUT} to be scaled higher, 2.5 V in the case of the AD580. In principle, this voltage can be raised to any practical level; for example, the selectable AD584 provides taps for 2.5, 5, 7.5, and 10-V operation.[6]

In practical applications, the amplifier is an invaluable feature. Besides its central role in optimizing the basic bandgap cell’s performance, it also provides scaling and low output impedance. The AD580, operating from supplies of 4.5-30 V, outputs 2.5 V at up to 10 mA, a useful feature for a variety of circuits.[7] It is available in tolerances as low as 10 mV, with TCs as low as 10 ppm/ $^{\circ}$ C (Table 1).

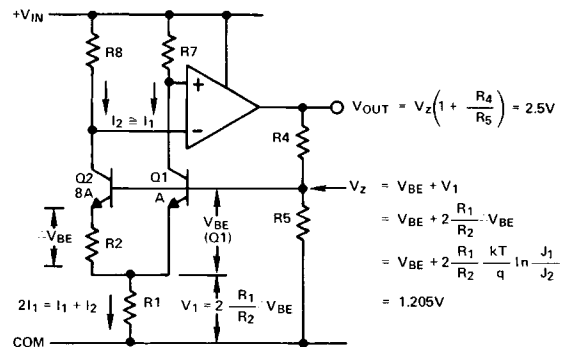

Figure 3. Functional diagram, AD580 precision bandgap reference

Table 1. Fixed Positive Output Three Terminal Monolithic IC References

| Device | Type ¹ (B, Z) | V_{OUT} (V) | Tolerance (+mV max) | Drift (ppm/ $^{\circ}$ C, max) | $+V_S$ (V) | Load Sensitivity ² | Sensitivity Line (μ V/V, max) | Noise ¹² | R_{TRIM} (Ω) \pm Range (V) | I_Q (mA, typ) | PTAT Output (mV/ $^{\circ}$ C) | Comment |
|---------------------------|-----------------------------|------------------|---------------------------|--------------------------------------|------------------------|----------------------------------|--|---------------------|--|--------------------------|--------------------------------------|-----------------|
| AD780 ^{8, 9, 11} | B | 2.5 | 1-5 | 3-20 | $V_{OUT}+1.5$ to 36 | 50 | 10 | 4 μ V, 100 | 25k, 0.1 | 0.75 | 1.9 | Precision 2.5 V |
| REF-43 | B | 2.5 | 15-50 | 10-25 | 4.5-40 | 50 | 5 | 220 (1 kHz) | 10k, 0.095 | 0.45 | 1.9 | Precision 2.5 V |
| AD680 | B | 2.5 | 5-10 | 20-30 | 4.5-36 | 100 | 40 | 250 | NA | 0.2 | 2.0 | Low I_Q |
| REF-03 | B | 2.5 | 15 | 50 | 4.5-33 | 250 | 125 | 6 μ V | 10k, 0.15 | 1.0 | 2.1 | Standard 2.5 V |
| AD580 | B | 2.5 | 10-75 | 10-85 | 4.5-30 | 1000 | 1-6 mV ⁷ | 8 μ V | NA | 1.0 | NA | 3 Pin TO-52 |
| AD1403 | B | 2.5 | 10-25 | 25-40 | 4.5-40 | 1000 | 3-4.5 mV ⁷ | 8 μ V | NA | 1.2 | NA | 3 Pin Mini-DIP |
| AD586 ¹¹ | Z | 5 | 2-20 | 2-25 ¹⁴ | 10.8-36 | 100-150 | 100 | 4 μ V, 100 | 10k, +6%, -2% | 2.0 | NA | Precision 5 V |
| REF-195 | B | 5 | 2-10 | 5-10 | 5.1-15 | 20-40 ¹³ | 20-40 ¹⁴ | 50 μ V | NA | 30 μ A ¹⁵ | NA | Note 10 |
| REF-05 | B | 5 | 15-25 | 8.5-25 ¹³ | 8-33 | 500 | 500 | 10 μ V | 10k, 0.3 | 1.0 | 2.1 | Note 5 |
| REF-02 | B | 5 | 15-100 | 8.5-250 | 8-33 | 500-2500 | 500-2500 | 10 μ V | 10k, 0.3 | 1.0 | 2.1 | Standard 5 V |
| AD587 ¹¹ | Z | 10 | 5-10 | 5-20 ¹⁴ | 13.5-36 | 100 | 100 | 4 μ V, 100 | 10k, +3%, -1% | 2.0 | NA | Precision 10 V |
| AD581 ⁸ | B | 10 | 5-30 | 5-30 | 13-30 | 500 | 200 | 40 μ V | NA | 0.75 | NA | 3 Pin TO-5 |
| REF-10 | B | 10 | 30-50 | 8.5-25 ¹³ | 13-33 | 800-1000 | 1000 | 20 μ V | 10k, 0.3 | 1.0 | NA | Note 6 |
| REF-01 | B | 10 | 30-100 | 8.5-65 | 13-33 | 800-1000 | 1000-1500 | 20 μ V | 10k, 0.3 | 1.0 | NA | Standard 10 V |

NOTES

NA = not applicable for device in question.

¹B = Bandgap, Z = Buried Zener.

² μ V/mA, max, I_L = 0-10 mA, Sourcing.

³Long term stability 100 ppm (max.) per 1khours.

⁴Long term stability 15 ppm (typ.) per 1khours.

⁵Similar to REF-02 with long term drift specified.

⁶Similar to REF-01 with long term drift specified.

⁷Total over applicable supply range.

⁸Operates in two-terminal mode.

⁹2.5 V & 3 V output modes.

¹⁰Low I_Q , low dropout, shutdown pin.

¹¹Optional noise reduction feature

¹²Typical, μ V p-p, 0.1 to 10 Hz or nV/ $\sqrt{\text{Hz}}$ at 100 Hz.

¹³ I_L = 0-30 mA, $+V_S$ = 6.3-15 V.

¹⁴ $+V_S$ = 5.1-15 V.

¹⁵5 μ A standby.

Zener-based references also benefit from careful buffering; and overall accuracy and stability are improved by including the Zener in the buffer circuit's feedback loop. Figure 4 depicts the basic circuit architecture of the hybrid IC AD27xx series. [8, 9] These devices have long provided stable +10-V, -10-V and ±10-V sources with very tight tolerances and TCs, as low as ±1 mV and 1-2 ppm/°C, performance only recently achieved by monolithic devices.

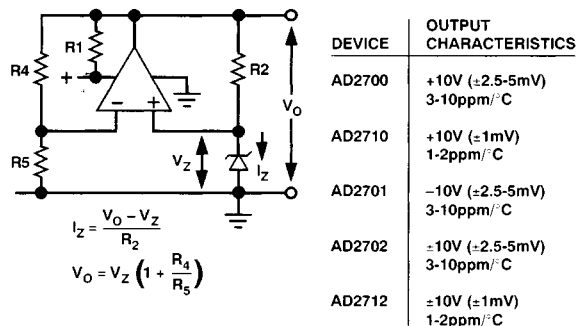

Figure 4. Precision Zener buffering architecture with gain provides regulated diode current for optimum TC.

Circuits of this type can feed back the optimum value of regulated current from the output $[(V_O - V_Z)/R_2]$ to operate a temperature-compensated diode at the op amp's + input. The Zener voltage is amplified using a pair of resistances whose ratio is laser-trimmed for accurate output voltage, $[(1 + R_4/R_5)V_Z]$. The op amp can drive load currents up to 10 mA with a typical output impedance of 50 $\mu\text{V}/\text{mA}$, and the inclusion of the diode in the feedback loop makes the device relatively insensitive to line-related errors, typically 125 $\mu\text{V}/\text{V}$ for the AD2710. To further reduce the low calibration errors, a pair of fine-trim terminals is provided. The +10-V- output devices operate as shown, while the ±10-V AD2712 adds a precision inverter for the negative output.

IC REFERENCE SPECIFICATIONS

Monolithic IC references come in a variety of functional styles, dominated by three-terminal types with fixed positive output(s).

The choice of bandgap or Zener technology determines the class of ultimate specifications and performance.

Figure 5 shows the standard basic pinout (input-2, output-6, ground-4) for +2.5-, +5-, and +10-volt IC references in 8-pin cans and DIPs. Additional pins may be used for important housekeeping details, such as optional trimming (e.g., R_{TRIM} at pin 5) or providing a PTAT kelvin-scale thermometer output—an inherent bonus feature in bandgap devices (“ V_{TEMP} ” at pin 3). In general, all references should use an adjacent RF-quality input bypass capacitor, C_1 , sometimes paralleled with larger C_2 for increased capacitance, to handle noisy sources and rapidly varying heavy loads. Some references may also allow (or require) an output bypass, C_{OUT} —or a noise-reduction capacitor connected to an internal point. Layouts should use a short, heavy (+) output conductor to minimize IR drops, while the (-) lead is less critical in this configuration, typically carrying ≤ 1 mA.

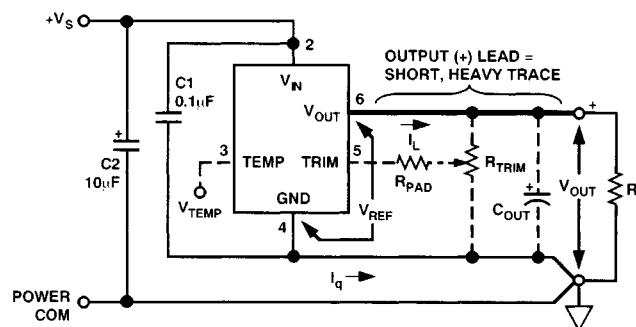

Figure 5. Standard positive-output three-terminal reference hookup (8 pin DIP pinout).

Table 1 is a summary of fixed-voltage three-terminal bandgap (B) and “buried”-Zener-based (Z) positive references. It compares the key device specs of output tolerance, drift, operating input supply range, sensitivity to load current (output impedance) and line voltage, noise, quiescent current, as well as trim range and PTAT thermometer availability. Comments and notes interpret and supplement the numerical specs. Table 2 compares references having selectable output voltage.

Table 2. Selectable Output Monolithic IC References

| Device | Type ¹ (B, Z) | V_{OUT} (V) | Tolerance (± mv max) | Drift (ppm/°C, max) | $+V_S$ (V) | Load Sensitivity ($\mu\text{V}/\text{mA}$, max, $I_L=0-10$ mA, Sourcing) | Sensitivity | | Noise | | Trim Range (±mV) | I_Q (mA, typ) | Tracking in Bipolar Mode (± mV, max) | Comment |
|----------------------|-----------------------------|--------------------------|----------------------------|---------------------------|--------------------------|--|--|--|------------------------|------------------------|------------------------|--|--|---------|
| | | | | | | | Line ($\mu\text{V}/\text{V}$, max) | Line Sensitivity (typ, nV/√Hz or μV p-p 0.1-10 Hz) | Trim Range (±mV) | Trim Range (±mV) | | | | |
| AD584 ^{8,9} | B | 2.5, 5, 7.5, 10 | 2.5-5, 7.5-30 | 5-30 ^[5] | $V_{OUT}+2.5$ to 30 V | 50 ^[7] | Note 10 | 50 μV | Note 11 | 0.75 | NA | Multiple positive output. | | |
| AD588 ⁹ | Z | ±5, +5/+10, -5/-10 | 1-5 | 1.5-6 ^[3] | ±13.5 to ±18 | 50 | ±200 ^[6] | 100 | 4 | 6 | 0.75 | Precision programmable low noise + TC, Kelvin sensing buffer amplifiers. | | |
| AD688 ⁹ | Z | ±10 | 2-5 | 1.5-6 ^[4] | ±13.5 to ±18 | 40 | ±200 ^[6] | 140 | 5 | 9 | 1.5-3 | Precision ±10 V, low noise + TC, Kelvin sensing buffer amplifiers. | | |
| REF08 | Z | -10 -10.24 | 30-40, 40-60 | 50-100 | -11.4 to -36 | 250 | 500 | 140 | 270 | 1.1 | NA | Dual negative output. | | |

NOTES

¹B = Bandgap, Z = Buried Zener.

²NA = not applicable for device in question.

³Long term stability (ppm) 15 (typ), 25 (max) per 1khours.

⁴Long term stability (ppm) 15 (typ) per 1khours.

⁵Long term stability (pm) 25 (typ) per 1khours.

⁶ T_{MIN} to t_{MAX}

⁷ppm/mA, 0-5 mA.

⁸Operates in two-terminal mode, 5 + 10 V.

⁹Optional noise reduction feature.

¹⁰0.002%/V, 15 to 30 V; 0.005%/V, $V_{OUT} + 2.5$ to 15 V

¹¹Determined by user resistances.

All Analog Devices monolithic IC Zener references employ a sub-surface breakdown technology, providing a salient improvement over the noise, drift, and reliability of surface-mode operated devices. [10] It was first applied in 1974, within the AD534 analog multiplier, [11] and later in DACs and other conversion products. The first stand-alone buried-Zener reference was the multiple-output AD588, a ± 5 -V, +10-V, -10-V precision unit, [12, 13] followed by the three-terminal +5-V AD586 and +10-V AD587, [14] and the negative-output REF08. Buried-Zener references offer the lowest drift, down to the 1-2-ppm/ $^{\circ}$ C range (AD588 and AD586), and the lowest noise as a % of nominal output, 100 nV/ $\sqrt{\text{Hz}}$ or less at 5 or 10 V (AD586, -587, -588). The multiple-output AD588 and AD688 (± 10 V) are listed in Table 2.

Tolerance: By choosing a unit specified for the required accuracy when possible, the user can avoid trimming (or gain scaling). This results in the best TC performance, since tight tolerances and low TCs usually go hand-in-hand. Tolerances as low as 0.04% can be achieved with the AD586, AD780, and REF195, while the AD588 goes as low as 0.01%. If trimming must be used, be sure to use the specific circuit recommended on the device data sheet, with no more range than necessary. For scaling beyond the recommended range, use a precision op amp and accurate-ratio, low-TC tracking thin film resistors.

Drift: The lowest-drift (long-term and temperature-related) references are monolithic buried-Zener and hybrid types using temperature-compensated Zeners. Maximum TCs as low as 1 ppm/ $^{\circ}$ C are available with the AD2710 hybrids, and 1.5 ppm/ $^{\circ}$ C with the AD588 and AD688. Close behind is the AD586, at 2 ppm/ $^{\circ}$ C; and the best bandgap is the AD780, at 3 ppm/ $^{\circ}$ C. Lowest maximum long term drift is 25 ppm/1000 hr, in the AD588.

Temperature drift can affect full-scale accuracy in systems using A/D and D/A converters, as indicated by Table 3. This table shows system resolution in bits (column 1), required drift rate for 1/2-LSB drift over a 100 $^{\circ}$ C change (column 2), and the voltages corresponding to 1/2 LSB for this 100 $^{\circ}$ C example for three reference voltages. Drift of <1.2 ppm/ $^{\circ}$ C is required to maintain 1/2 LSB error at 12 bits, but lesser temperature spans will require less-stringent drifts.

The temperature drift of references is seldom monotonic; there may be several reversals over the rated temperature span. Modern practice is to measure output at several temperatures, so as to guarantee a maximum error band applicable to the temperature range. The

Table 3. Reference Temperature Drift Requirements for Various System Accuracies (1/2 LSB Criteria, 100 $^{\circ}$ C Span)

| Bits | Required Drift, (ppm/ $^{\circ}$ C) | 1/2 LSB Weight (mV), Various FS Ranges | | |
|------|-------------------------------------|--|------|-------|
| | | 10 V | 5 V | 2.5 V |
| 8 | 19.53 | 19.53 | 9.77 | 4.88 |
| 9 | 9.77 | 9.77 | 4.88 | 2.44 |
| 10 | 4.88 | 4.88 | 2.44 | 1.22 |
| 11 | 2.44 | 2.44 | 1.22 | 0.61 |
| 12 | 1.22 | 1.22 | 0.61 | 0.31 |
| 13 | 0.61 | 0.61 | 0.31 | 0.15 |
| 14 | 0.31 | 0.31 | 0.15 | 0.08 |
| 15 | 0.15 | 0.15 | 0.08 | 0.04 |
| 16 | 0.08 | 0.08 | 0.04 | 0.02 |

rated drift in ppm/ $^{\circ}$ C is defined as the slope of a diagonal drawn between opposite corners of a box that bounds the applicable temperature range and the allowable maximum change. For example, the 5 ppm/ $^{\circ}$ C, 5-volt AD586L (25 μ V/ $^{\circ}$ C) has an allowable change of 1.75 mV over a 70 $^{\circ}$ C range (this technique is discussed in greater detail on the AD586 data sheet).

Supply Range: Reference ICs generally require a supply range from about 3 V above rated output, to 30 V or more, except for devices designed for low dropout, such as the REF195 and the AD780. At low currents, the REF195 can maintain 5-V output with input voltage as low as 5.1 V (0.1-V dropout).

Load Sensitivity: Load sensitivity, or output impedance, is usually specified in μ V/mA of load current (or m Ω), for output source currents of 0-10 mA. A reasonable value at low frequencies is 100 m Ω or less (AD780, REF43, REF195), but without due care, external wiring drops can add a comparable amount of series impedance, producing additional error (see Figure 5). Errors depending on load current are minimized with short, heavy conductors on the (+) output, and return wires to reference and power common from the low end of the load. For the highest precision, buffer amplifiers and separate force-sense (or Kelvin) connections—like those provided in the AD588 & AD688—can guarantee a precise voltage at the point-of-loading. Several of the applications illustrate Kelvin sensing.

Figure 6 is a plot of *dynamic* output impedance as a function of frequency for three 2.5-V references. These data were collected with a high resolution test setup using an Audio Precision System One, with software adapted from "IMPD"*, modified for 4-terminal high-resolution bandpass-mode operation. Input to the device under test is +15 V dc, and the test signal is 0.83-mA rms swept at 20-200-kHz, superimposed on a dc load of 2 mA.

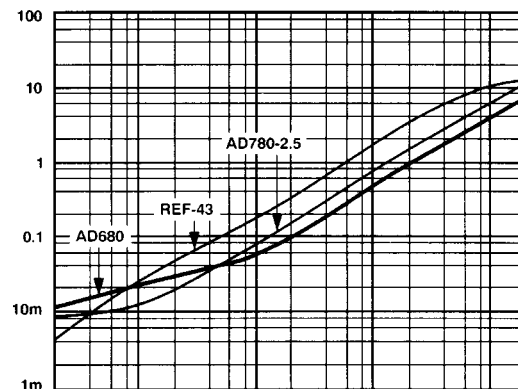

Figure 6. AD680, AD780, REF43; output impedance (ohms) vs. frequency (Hz); (V_{IN} (DC) = 15 V, I_L (DC) = 2 mA, I_L (AC) = 0.83 mA rms)

The plot compares their output impedance as a function of frequency. The characteristic 6-dB/octave rise above 100 Hz is essentially inductive (8-25 μ H), while at low frequencies the impedance approaches or reaches a constant resistance in the vicinity of 10 m Ω for these devices. Some devices allow additional output load capacitance, which can be employed to further decrease output impedance at higher frequencies.

*Debi Brimacombe, "Generating Impedance vs. Frequency Plots With System One", AUDIO.TST, November 1992.

Line Sensitivity: Line sensitivity, the ratio of output change to a change of input, is less than 50 $\mu\text{V/V}$ (-86 dB) in the REF43, REF195, AD680 and AD780. For dc and very low frequencies, such errors are easily masked by noise.

Plots of line rejection vs. frequency show susceptibility of a device to wideband noise on the input line (Figure 7). Data were collected with a high-resolution, screened and guarded test setup employing an Audio Precision System One analyzer operating in a bandpass-filtered crosstalk mode, for a dynamic range in excess of 130 dB. The device input is +15 V dc, and the output load is 1 mA. The test signal, superimposed on the input, is at 1 V rms, swept from 20 Hz to 200 kHz. For these plots, the V_{IN} 0-dB reference is 1 Vrms, and test-circuit residual noise below 1 kHz is $\cong -140$ dB. Because of the bandpass nature of these measurements, in some instances they may not directly compare to results using wideband methods (which tend to become noise-limited at -90 to -100 -dB levels).

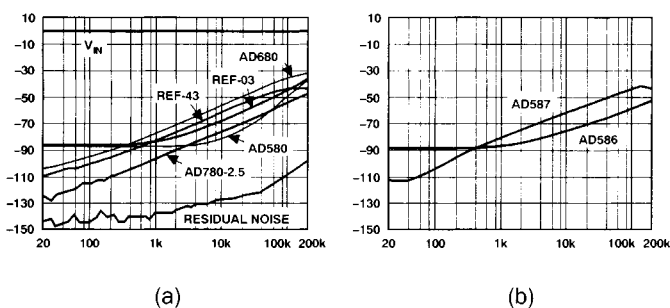

Figure 7. Various references, line rejection (dB) vs. frequency (Hz); (V_{IN} (DC) = 15 V, I_{I} (DC) = 2 mA, V_{IN} (AC) = 1 V rms). a. 2.5-V bandgap types. b. Buried Zener types.

Figure 7a shows line-rejection vs. frequency for a group of 2.5-V bandgaps. The recent AD680, AD780 and REF43 show rejection of 100 to 130 dB at low frequencies, decreasing to 40-55 dB at 100 kHz. The AD580 and REF03 have more-limited rejection ($\cong 90$ dB) below 1 kHz, but their behavior is comparable at the higher frequencies.

Line rejection for two 5- and 10-V buried-Zener devices (b) was measured in standard operation (no “noise reduction” used). The AD586 has greater rejection at high frequency; the AD587 at low frequency.

For references requiring greater line rejection, simple input filtering can be effective. A 100- Ω decoupling resistance with a 1- μF bypass filters frequencies above 1.6 kHz; the input DC headroom suffers only 0.2 V increase for 2-mA loading. This step is a wise precaution when references must derive their power from switch-mode power supplies. Additional output capacitance (where allowable) can also be helpful. Alternatively, line rejection can be increased with a preregulator, either a 78Lxx type regulator or stacked reference. [7]

Noise: Not all manufacturers specify the noise generated within a reference; when it is specified, there is little uniformity on how to measure it and present the data. For example, some devices are characterized for peak-to-peak noise in a 0.1-10-Hz bandwidth, others are specified in terms of rms for a specified bandwidth, and yet others in noise spectral density ($\text{nV}/\sqrt{\text{Hz}}$ rms) at a given frequency. The most useful characterization would be a plot of noise spectral density over a range of frequencies, since it can be used for

calculating any of the other specifications. Any noise fed through from the supply due to line sensitivity must be added (root-sum-of-squares) to the noise generated by the device.

Noise is an important characteristic in references because it limits accuracy and introduces uncertainty in high-resolution, wide-bandwidth systems. A noisy reference source used in a conversion system can result in reduced resolution. For low-frequency measurement systems, peak-to-peak specifications in the time domain are useful, because noise adds to the uncertainty of each unique data point. In higher-frequency systems, rms values for noise are more useful, because information usually has more redundancy, and signal-to-noise ratio, which compares their rms values, becomes a relevant criterion.

Gaussian noise is theoretically unbounded; for a given rms level, very large peak-to-peak values are possible, but their probability decreases very rapidly (for example, the probability of $14\times$ rms peak-to-peak is only 2.6×10^{-12}). Conventionally, noise specs use a $6\times$ ratio of p-p p/rms (0.27% probability of higher peaks).

For white noise (constant noise spectral density, e_n $\text{nV}/\sqrt{\text{Hz}}$), the rms value in a given bandwidth is the product of e_n and the square root of bandwidth, i.e., $e_n\sqrt{B}$, where B is a “brick-wall” noise bandwidth, $f_2 - f_1$. For converters, of resolution N bits, the target value of errors, 1/2 LSB, is $V_{\text{REF}}/2^{N+1}$. So, for 1/2-LSB rms white noise, the noise spectral density has to be

$$e_n \leq \frac{V_{\text{REF}}}{2^{N+1}\sqrt{B}}$$

and for 1/2-LSB peak-to-peak rms white noise, divide by 6:

$$e_n \leq \frac{V_{\text{REF}}}{6 \times 2^{N+1}\sqrt{B}}$$

For a 10-V, 12 bit, 100-kHz system with an unfiltered reference, the p-p noise requirement is modest, 640 $\text{nV}/\sqrt{\text{Hz}}$. Table 4 provides the set of required values for resolutions from 12 to 16 bits using 10-, 5-, and 2.5-V references. Note that the required e_n decreases with increased resolution, decreased V_{REF} , and increased bandwidth. However, the user can control the bandwidth with filtering, to make a noisy reference more useful.

Table 4. Reference Noise Requirements for Various System Accuracies (1/2 LSB/100 kHz Criteria)

| Bits | Noise Density ($\text{nV}/\sqrt{\text{Hz}}$), Various FS Ranges | | |
|------|---|-----|-------|
| | 10 V | 5 V | 2.5 V |
| 12 | 643 | 322 | 161 |
| 13 | 322 | 161 | 80 |
| 14 | 161 | 80 | 40 |
| 15 | 80 | 40 | 20 |
| 16 | 40 | 20 | 10 |

From Tables 1 and 2, bandgap and Zener references are available with noise densities from 100 $\text{nV}/\sqrt{\text{Hz}}$ (usually specified at 100 Hz) and low-frequency noise from 4 μV p-p. Figure 8 illustrates the noise as a function of bandwidth and frequency for the AD780 (a) and the AD587 (b). These plots are taken with a swept bandpass filter with a gain of 100 and noise bandwidth, $B = f_2 - f_1 = 0.2316F$, in the vicinity of each frequency, F . Since the bandwidth is proportional to F and noise is proportional to \sqrt{B} ,

the plotted noise will rise at about 3 dB per octave for white noise (constant e_n). At a given frequency, “F”, e_n can be calculated by dividing the reading by $100 \times \sqrt{(0.2316F)}$ (approximately $48\sqrt{F}$, about $1522 \sqrt{\text{Hz}}$ at 1 kHz).

For example, the AD780 at 2.5 V (averaged plot through lower curve) reads about $160 \mu\text{V}$ at 1 kHz, whence the noise density is $160 \times 10^{-6} / 1522 \approx 105 \text{ nV}/\sqrt{\text{Hz}}$, as expected. The noise at 10 kHz is about $460 \times 10^{-6} / (48\sqrt{10000}) \approx 96 \text{ nV}/\sqrt{\text{Hz}}$. Noise in the 3-V mode is proportionally higher. These curves reflect standard

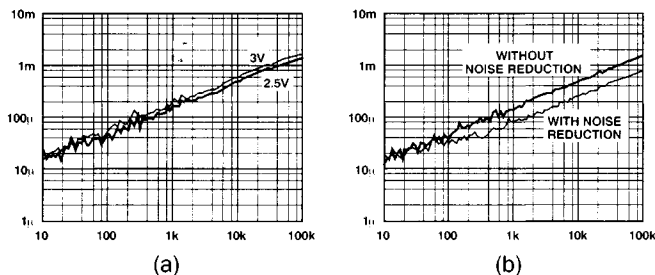

Figure 8. Various references, bandpass noise ($V \times 100$) vs. bandpass frequency (Hz); (I_L (DC) = 2 mA). a. AD780, 2.5- and 3-V modes. b. AD587, with & without noise-reduction capacitor.

operation for the AD780; when the suggested noise-reduction capacitors are used, the noise at 1 kHz and 10 kHz is reduced to 53 and 32 $\text{nV}/\sqrt{\text{Hz}}$, respectively (not shown).

Data is plotted in Figure 8b for the AD587 in standard operation (upper), and with the recommended noise bypassing (lower). The noise is reduced by about 5 dB, from 200 Hz to 100 kHz; for example, at 1 kHz the reduction is from about $106 \text{ nV}/\sqrt{\text{Hz}}$ to $59 \text{ nV}/\sqrt{\text{Hz}}$. Noise bypassing works similarly for AD586, AD588 and AD688. The capacitor used should be a low leakage type (e.g., compact stacked film) placed close to the pin.

A useful alternative with any reference is a dc-accurate post-filter stage. This involves a low-impedance single- or multiple-pole low-pass filter, buffered by a precision low-noise op amp; it passes the reference voltage while removing high frequency noise (an example is shown in detail below).

Reference pulse response: Often of concern in reference applications is the transient change of output voltage in the presence of stepped loads. Fast load changes of up to full-scale current perturb the output voltage, often beyond the rated error band. Key questions: how quickly does the output transient recover to within the rated accuracy band after a load change? Can anything be done to reduce the effect?

For example, Figure 9 shows the response of a REF43 IC to a 10-mA load step, for conditions of no output decoupling (a) and with the recommended decoupling network (b) [10 μF tantalum in parallel with 0.01 to 0.1 μF ceramic from V_{IN} and V_{OUT} to ground]. Without decoupling, the output has a large spike, settling to within $\pm 2.5 \text{ mV}$ in 3-4 μs and producing a further disturbance in circuits served by the reference. When decoupled, the output remains within the error band, changing only slightly.

For references with similar dynamics to the REF43, output decoupling is useful in maintaining control. However, additional output capacitance may or may not be allowable towards buffering a given reference type against transient loads, so specific data-sheet recommendations should be followed.

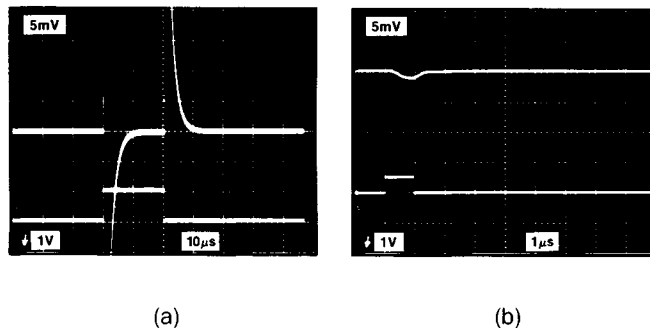

Figure 9. REF43 pulse response for 0-10-mA load change, with and without decoupling. a. Response with no decoupling. b. Response with output decoupling of 1 μF & 0.01 μF .

REFERENCE CIRCUIT APPLICATIONS

Shunt references: As noted earlier, shunt mode references can be used in either polarity, but they have the disadvantages of limited drive and relatively high output impedance; these tend to restrict them to applications with limited ranges of load variation.

Figure 10 illustrates a shunt-mode application, using two-terminal devices and three-terminal devices with V_{IN} and V_{OUT} jumpered for two-terminal operation. Here, an AD589 is used with a negative supply to provide a regulated negative reference. All shunt-operated references should be designed with careful attention to dc currents. R_S must be selected appropriately to maintain shunt current, I_D , in a limited range for any specified combination of load current, I_L , and supply voltage, V_S . With the AD589, R_S is chosen to allow 1.8 mA to flow with the magnitude of V_S 10% low. This will allow a 0 to 1.5-mA load current range, and the device will remain in a safe range with the load removed and $|V_S|$ 10% high. The AD589's typical R_Z of 0.6 Ω holds output changes $< 1 \text{ mV}$ for a 1.5-mA I_L change.

A bypass capacitor is recommended to reduce high-frequency noise and ac impedance; the value shown in the figure can be increased for further impedance reduction. As the table shows, a wide range of voltages are available—with the same device in some cases (AD584, AD780); the AD780 provides the lowest output impedance.

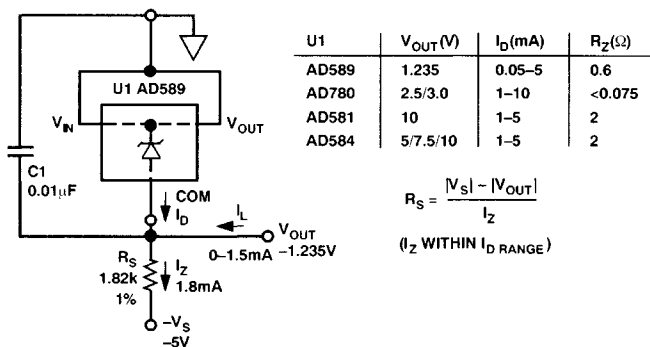

Figure 10. Shunt reference IC operation.

Negative references: Positive voltage references are the most widely produced and used, but negative references are often required. While this can be accomplished with a simple shunt reference, it is usually more desirable to operate negative references

as current-buffered voltage sources, to avoid the shunt circuit's loading restrictions.

A simple technique is to cascade a stable positive voltage reference with a precision inverting scaling amplifier, using a high quality op amp, such as an AD707 or OP177, and a high-accuracy resistor pair. This approach is workable and straightforward but its cost/performance is limited by the tradeoff between resistor accuracy and the cost of precision resistors—which can greatly exceed the cost of the op amp.

A more direct approach for a negative reference is to use an IC specifically designed for such use, namely the REF08 (Table 2). The buried-Zener REF08 is designed as a 10-V three-terminal negative reference; it functions as a mirror image of 10-V positive references, such as the AD587. It is applied in simple fashion, furnishing a -10-V output with tolerances of $\pm 30\text{ mV}$ or $\pm 40\text{ mV}$; a $\pm 270\text{-mV}$ trim range is available. With pin 4 strapped to ground, it furnishes an alternative $-10.24\text{ V} \pm 40$ or $\pm 60\text{ mV}$, suitable for easy scaling in 10-mV/LSB 10-bit applications. The REF08 is available with TCs of 50 or 100 ppm/°C.

Another alternative is to “invert” positive IC references, a design approach valuable because of the wider array of high-performance references from which to choose (Table 1); and the elimination of resistors and their scaling/drift errors. Resistorless inverters basically enclose the IC reference within a precision op amp feedback loop, driving the common (or negative) terminal so as to maintain the normally positive output at ground; thus the reference IC's common terminal is driven at $-V_{REF}$. [15]

An example of this scheme is illustrated in Figure 11, using an AD780 (or other positive three-terminal IC) for U1 as the reference IC. Overall, this circuit supplies a stable $V_{OUT} = -V_{REF}$, where V_{REF} is the 2.5-V (or other) voltage at U1's output (with no load). Thus the circuit inverts a positive reference's output, without the expense or errors of a precision resistor pair. The full dc precision of the basic reference IC is easily maintained, due to the buffering by the op amp, U2, while ac performance can be optionally improved even further.

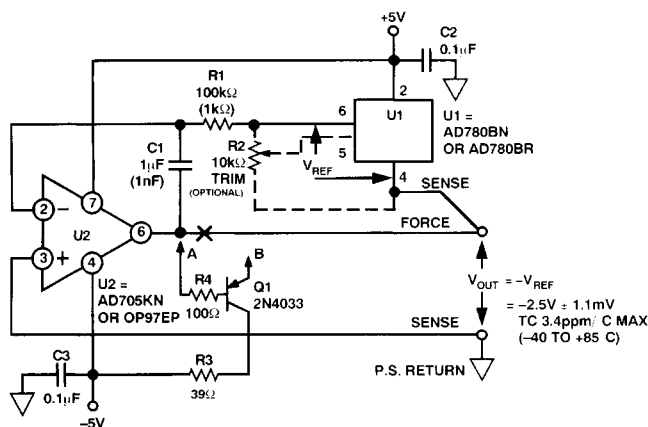

Figure 11. Buffered “inverted” negative reference.

DC accuracy is optimized largely by careful selection of the U1 device from Table 1, for initial tolerance, drift, etc. The drift characteristics of the op amp are usually less important, but may not be negligible. For example, a $1\text{ }\mu\text{V}/^\circ\text{C}$ drift in U2 is equivalent to a negligible $0.4\text{ ppm}/^\circ\text{C}$ drift in U1's 2.5 V. U2 should also have $V_{OS} < 100\text{ }\mu\text{V}$, for negligible contribution to tolerance error. Given

this drift/accuracy criterion, U2 should be a high DC precision type such as an AD705KN or OP97EP when used with a low-drift IC such as the AD780 (or other). Current drain for the unloaded circuit is typically 1.2 mA.

U2 determines the output drive capability of the circuit. For lowest self-heating errors, dissipation in U2 should be minimized, with current outputs restricted to 10 mA or less (including the quiescent current of U1). Substantially higher currents of say 50 mA can be accommodated without side effects using a PNP booster transistor such as a 2N4033, inserted between points “A” and “B”. Lower output impedance in wideband applications is available with the AD820 for U2, with some tradeoffs in dc accuracy and drift. Connecting the FORCE and SENSE leads as noted minimizes wiring-drop errors.

Filter R1-C1 sets the integrating time constant in U2 to promote stability and noise reduction. With the choice of larger values, the broadband noise of U1 is reduced to a minimum, and overall noise is close to the noise of U2; a typical measurement is $< 20\text{ nV}/\sqrt{\text{Hz}}$ at 1 kHz. If attenuation of reference noise is not necessary, the smaller values (in parentheses) should be used. Using the devices in the figure, the (untrimmed) output is $-2.5\text{ V} \pm 1.1\text{ mV}$, with a TC of 3.4 ppm/°C. U1 and U2 are available in both SOIC and DIP packages.

Shunt mode references, as essentially floating ICs, are used for positive or negative outputs. When used with a buffer op amp, in an inverted configuration, their load-current restrictions are removed. Figure 12 is an example of a buffered inverted shunt-mode negative reference. This circuit is similar to Figure 11, but includes input resistor, R1, to supply bias current for the reference diode. Because the op amp's (+) input is grounded, the feedback loop holds the positive terminal of D1 at virtual ground. As a result, the amplifier output is driven at the reference voltage, which, in the case of the AD589, is -1.235 V . The diode requires only a small bias current; the available load current is then limited only by the output specification of U1 (15 mA minimum).

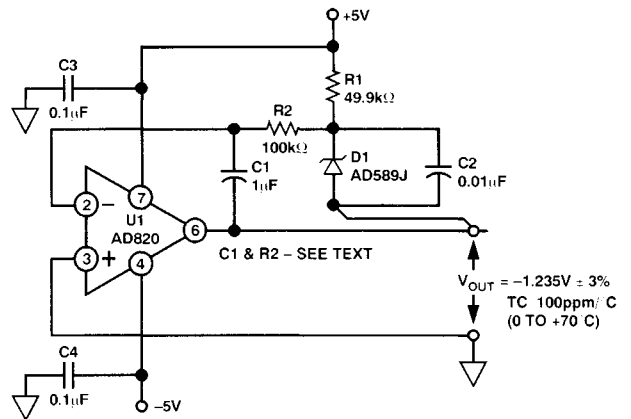

Figure 12. Buffered “inverted” low noise shunt reference.

This scheme can also be applied for the opposite output polarity (positive output), with D1 reversed and R1 returned to a negative voltage. For other supply voltages, R1 can be chosen for a standard value of D1 bias current, say 100 μA . Note that this principle applies for other voltages, using devices designed to operate in the shunt mode (see table of Figure 10). Kelvin sensing, used as shown, maintains high dc accuracy at the load.

As in the circuit of Figure 11, integrator time constant, R_2C_1 , can be optionally chosen for noise filtering as shown; the noise is reduced to that of the op amp used. Using the AD820, the filtered noise measures ≈ 15 nV/ $\sqrt{\text{Hz}}$ at 1 kHz, and the circuit's output impedance is ≈ 0.05 Ω at 1 kHz. Without this filtering (much smaller time constant), noise output of the circuit is that of the AD589, or ≈ 200 nV/ $\sqrt{\text{Hz}}$. In this simple circuit, the output accuracy is $\pm 3\%$, that of D1. Trim is possible, using a resistive divider across D1, feeding R2, to adjust the output voltage.

Low-noise references for wide-dynamic-range converters: High-resolution converters, including Σ - Δ and (especially) high-speed types, benefit from the improved noise and load-capacitance tolerance of recently available references.

Figure 13 shows the AD780 used as a 3-V reference for the AD711x series of >20 -bit Σ - Δ converters. The 3-V scaling (rather than 2.5) enhances the dynamic range of this and many other 5-V single-supply converters, while the ≈ 4 - μV p-p noise (0.1-10 Hz) minimizes overall system noise.[16] In addition, the large decoupling capacitance at the converter's REF IN pin minimizes voltage errors due to transients. These same factors also enhance performance of wider bandwidth converters such as the 16 bit AD7884.[17]

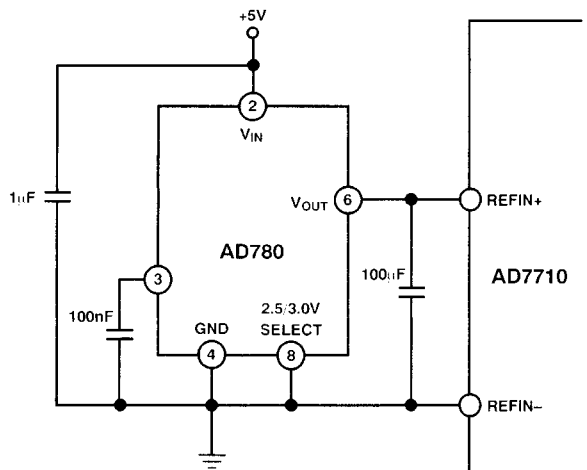

Figure 13. Precision 2.5/3-V reference for the AD7710-series high-resolution Σ - Δ ADCs.

Current-boosted 50-mA three-terminal reference: For highest dc accuracy, output current of reference ICs should be kept well within the 10-mA rating. Thus for loads of substantially more than about 5 mA, some form of booster should be considered. This can be accomplished with the addition of a PNP pass transistor, as shown in Figure 14.

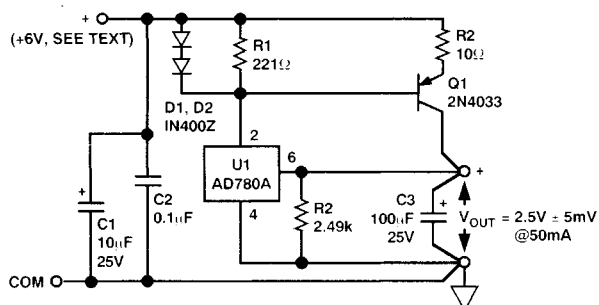

Figure 14. 50-mA current-boosted three-terminal reference with current limiting.

In this circuit the input current of U1 through R1 develops a base drive for Q1, whose collector provides the bulk of the load current. U1 never is called upon to furnish more than a few mA, so this minimizes internal temperature differential and drift. Short-circuit protection is provided by the diode clamps which limit drive to Q1, at about 80 mA of load current.

Other references and output voltages can be used for U1, but may require some R1 adjustment, dependent upon their I_q . The booster current-limiting configuration causes the dropout voltage of the circuit to increase, and operation from a +5-V supply may be marginal, especially when references having greater dropout voltage are used for U1.

Besides increasing output current, Q1 decreases output impedance; the loaded output impedance at 1 kHz is <10 m Ω , about 10-20 times better than for the AD780 alone. C_3 is high to minimize high-frequency output impedance (400 m Ω at 100 kHz), but smaller values can also be used. If an input voltage appreciably more than +6 V is used, heat sinking may be needed for Q1.

Bipolar-reference bridge driver: For optimum operation of a dc bridge, bipolar drive is useful; it virtually eliminates the output common mode component. Figure 15 shows an implementation using either an AD588 or AD688 buried-Zener reference with Kelvin sensing of the drive voltages at the bridge.

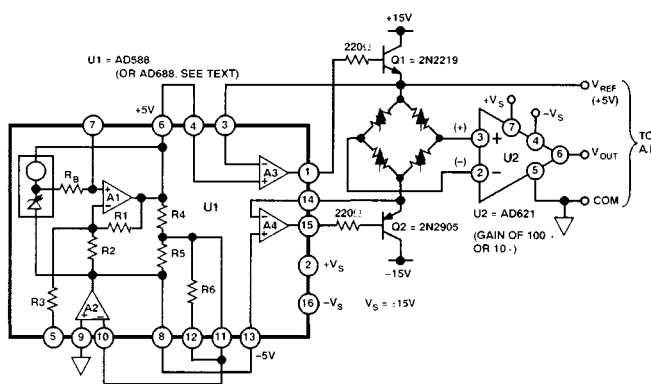

Figure 15. Bipolar (± 5 -V) bridge with precision in-amp.

The AD588 Zener cell and A1 produce a 10-V total potential, which can be shifted either above or below common, or split into ± 5 V by R4 and R5, with ground enforced by A2, as shown here. The basic ± 5 -V signals then appear at pins 6 and 8; they drive Kelvin sensing follower-amplifiers A3 and A4. The amplifiers sense the voltage at each end of the bridge and drive those points through external current boost transistors Q1 and Q2, respectively, forcing the bridge end points to equal the ± 5 V output of the reference, within the symmetry specifications of the AD588 (± 1.5 mV). Metal-can transistors are used for Q1 & Q2, for best dissipation at the 30-mA drive level. For ± 10 -volt drive, the AD688 can also be used in a similar fashion.

The output sensing in-amp is the AD621, which provides tap-selectable gains of 10 and 100, with a gain tempco of 5 ppm/ $^{\circ}\text{C}$ or less, lower in fact than can easily be done with readily available gain set resistors and a single ended amplifier. The scaled bridge output signal can drive an ADC; which can also use the +5-V bridge reference voltage as the conversion reference.

30-mA reference with shutdown: The REF195 bandgap reference is like the other references of Table 1; but it has a unique shutdown capability, which allows a precision 5-V output to be turned ON and OFF by a TTL/CMOS compatible digital input, as shown in Figure 16. It has a low dropout of 0.5 V at 10 mA and low current

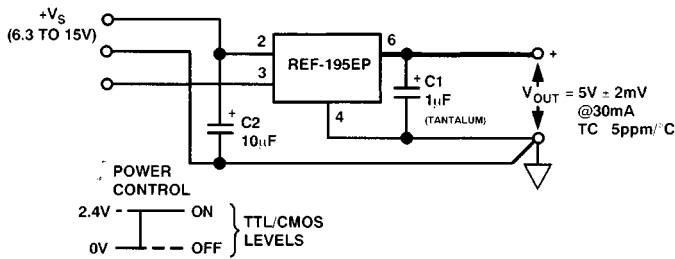

Figure 16. 30-mA reference with shutdown.

drain for both quiescent and shutdown states, 45 and 15 μA (max), respectively. For inputs in the range of 6.3 to 15 V, the REF195EP shown can furnish 5 V (± 2 mV) for loads of up to 30 mA, with a 5-ppm/ $^{\circ}\text{C}$ max TC.

The shutdown pin (3) is controlled by TTL or CMOS logic levels, with a "1" (or $+V_S$) commanding the output ON, while a low input shuts it OFF. With a 1- μF load bypass capacitor (the minimum recommended), transition OFF-ON time is several hundred μs . This OFF-ON transition time will be load dependent, increasing for higher C_L values. ON-OFF transition timing is determined by the load current and C_L .

To maximize DC accuracy in this circuit, the output of U1 should be connected directly to the load with short heavy traces, to minimize IR drops. The common pin is less critical, due to the much smaller current returning to the device.

Low noise 2.5/5/10-V reference: As noted earlier, voltage reference noise can contribute to system error. But the output of a reference can be buffered and filtered to effectively lower wideband noise by an order of magnitude or more.[18] For example, the low-noise reference circuit of Figure 17, using simple filtering, combines good ac and dc performance. It comprises a reference, U1, and a low-noise, buffered output circuit. Final output noise is largely determined by U2, and can range from under 2 nV/ $\sqrt{\text{Hz}}$, to 20 nV/ $\sqrt{\text{Hz}}$ or more at 1 kHz, depending on the device.

The basic reference voltage is set by U1, a 2.5, 5 or 10-V IC chosen from Table 1 for required accuracy and drift. This circuit uses an AD586MN, a 5-V (± 2 mV) buried-Zener reference with a 2 ppm/ $^{\circ}\text{C}$ drift and low 1/f noise. U1's stable 5-V output is applied to a R1-C1/C2 noise filter, using electrolytic capacitors for a low corner frequency. DC leakage errors are minimized by bootstrapping C1 so as to see only the small R2 dc drop as bias, effectively lowering leakage to negligible levels. The filter corner frequency is about 1.7 Hz, providing about 35 dB of attenuation at 100 Hz. Attenuation is modest below 10 Hz, so reference choice is still important to noise performance at low frequencies.

The filter's low-noise, dc-accurate output is buffered by a unity-gain buffer using an OP113EP low-dc-error, low-noise op amp. With less than ± 150 μV of V_{OS} error and less than 1 $\mu\text{V}/^{\circ}\text{C}$ drift, the buffer's dc performance will not compromise accuracy/drift of Table 1 references. The OP113 has a typical current limit of 40 mA, more current than IC references usually provide.

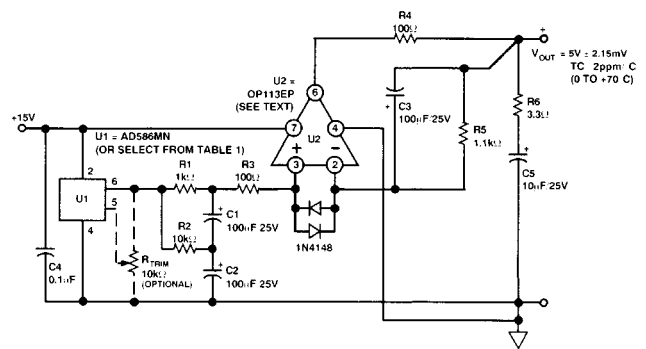

Figure 17: Low-noise 2.5/5/10-V reference.

While the single-supply OP113 is useful over the entire 2.5-10-V range, even lower-noise op amps are available for 5-10-V use. The AD797 has measured 1-kHz noise less than 2 nV/ $\sqrt{\text{Hz}}$, compared to about 6 nV/ $\sqrt{\text{Hz}}$ for the OP113. Other 5-10-V range possibilities include the OP27 and OP176. ▣

REFERENCES

1. Sirio Sconzo, "Ultra Stable Semiconductor Voltage Reference", Transistron Corp. Application Note AN-1352B, March 1963.
2. J. McKoy, "Selecting the Right TC Zener Diode", *EEE*, January 1965.
3. Bob Widlar, "New Developments in IC Voltage Regulators", *IEEE Journal of Solid State Circuits*, vol. SC-6, February, 1971.
4. Paul Brokaw, "A Simple Three-Terminal IC Bandgap Voltage Reference", *IEEE Journal of Solid State Circuits*, vol. SC-9, December, 1974.
5. Paul Brokaw, "More About the AD580 Monolithic IC Voltage Regulator", *Analog Dialogue*, 9-1, 1975. [out of print]
6. Mike Timko, Goodloe Suttler, "Monolithic Precision Multiple Voltage Reference", *Analog Dialogue*, vol. 12-2, 1978. Circle 6
7. Walt Jung, "Applications of the AD580", *Analog Dialogue*, 9-2, 1975. [out of print]
8. Jerry Gunn, "10-Volt (± 1 mV) References", *Analog Dialogue*, vol. 10-1, 1976. Circle 7
9. Ron Knapp, "Stable High Accuracy 10.0000V References", *Analog Dialogue*, vol. 15-1, 1981. [out of print]
10. Analog Devices, *Analog-Digital Conversion Handbook*, 3d. edition, Prentice Hall, 1986. Use the book purchase card or get in touch with Analog Devices Literature Center
11. Barrie Gilbert, "A High Performance Monolithic Multiplier Using Active Feedback", *IEEE Journal of Solid State Circuits*, Dec. 1974.
12. Bill Thompson, "Monolithic Precision Voltage Reference", *Analog Dialogue*, vol. 21-1, 1987. Circle 8
13. Bill Thompson, "Stable Reference IC Simplifies the Design of Analog Systems", *EDN*, January 21, 1988.
14. "Two New High-Precision Monolithic Voltage References", *Analog Dialogue*, vol. 21-2, 1988. Circle 9
15. Walt Jung, "Positive Reference-Voltage IC is Flipped Negative by Adding a Single Component", *Electronic Design*, February 15, 1978.
16. Joe Buxton, "High Accuracy A/D Conversion", Chapter 6 within *System Applications Guide*, Analog Devices, 1993. Use the book purchase card or get in touch with Analog Devices Literature Center
17. Walt Kester, James Bryant, "Interfacing to High Speed ADCs", Chapter 13 within *System Applications Guide*, Analog Devices, 1993. See item 16
18. Walt Jung, "Build an Ultra-Low-Noise Voltage Reference", *Electronic Design*, Analog Applications Issue, June 24, 1993.